

THE ONE THAT STARTED IT ALL

**UNDER
TAILGATE
CROSS
CONVEYOR** **BERMING
MACHINE**

The CRE-960 Berming Machine, designed to efficiently spread materials from a dump truck onto a berm, embodies Concord's mission: making tough tasks easier with a machine that's simple to operate, easy to maintain, and built to last.

Concord's founder, Glen Warfield, first built the CRE-960 in his garage. Although Concord Road Equipment quickly outgrew that space, our mission remains the same: to manufacture solutions and forge the road ahead. Since 1976, the CRE-960 Berming Machine has seen numerous design enhancements and accessory additions, reflecting our ongoing commitment to innovation in the municipal, construction, and industrial markets.



(800) 942-ROAD

ConcordRoadEquipment.com



(800) 842-ROAD
(440) 357-5344

SALES@CONCORDROADEQUIPMENT.COM

8200 TYLER BLVD. SUITE H,
MENTOR, OHIO, 44060



Options Shown

082624

LITBERMING_A

CRE-960 BERMING MACHINE

CONCORD'S LINE OF BERMING MACHINES AND ACCESSORIES ARE POWERFULLY VERSATILE.

Whether it's berming road shoulders, building curbs, patching asphalt, filling sand bags, backfilling trenches, repairing washout damage, or spreading ice control materials, the CRE-960 Berming Machine does it all.

BASE UNIT FEATURES

CRE-960-18B

Direction of belt reverses on-the-go, courtesy of standard quick-disconnect fittings.

Conveyor sealing skirts are self-adjusting. Conveyor to truck skirt creates tight seal regardless of dump body angle.

Material chute can be mounted on either the streetside or curbside of machine.

Hinged discharge door on streetside and curbside.

All external flange bearings and shaft ends are protected by easily removable access covers.

All bearings are external flange type and are serviceable with grease fittings.

Take-up bearings allow safe and easy adjustment and belt tracking.

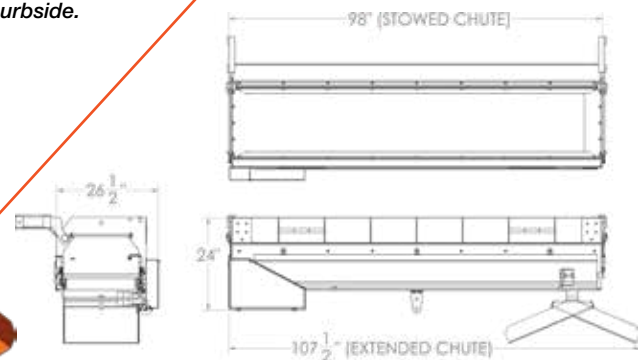

**Standard model primed & painted in Omaha Orange. All models available in 304 stainless steel.*

MOUNTING KITS



CRE-960-18SL

Self-leveling mounting kit includes full width saddle support that keeps all weight between pivot points, allowing level machine operation through dump cycle.



CRE-960-18FL

Folding leg and winch mounting kit with chain takeups allows user to move machine from one vehicle to another at the job site, without tools, in just minutes.

OPTIONS & ATTACHMENTS



BACK GUARD

CRE-960-18BG • 12" back guard extension. (Standard 7")

LED CLUSTER

CRE-960-18LG • Stop-tail-turn LED & 3-Light LED cluster recessed into rear cover. (Vehicle must be equipped with a trailer lighting receptacle.)

SPINNER ASSEMBLY

CRE-960-18SP • Adjustable material spinner/sander assembly with deflector & 18" steel disk (Polydisk also available).

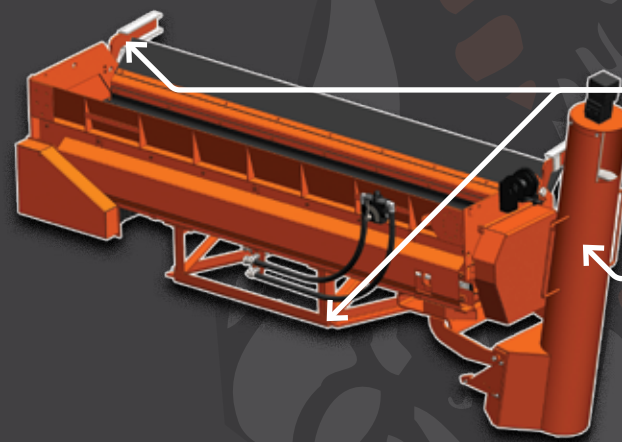
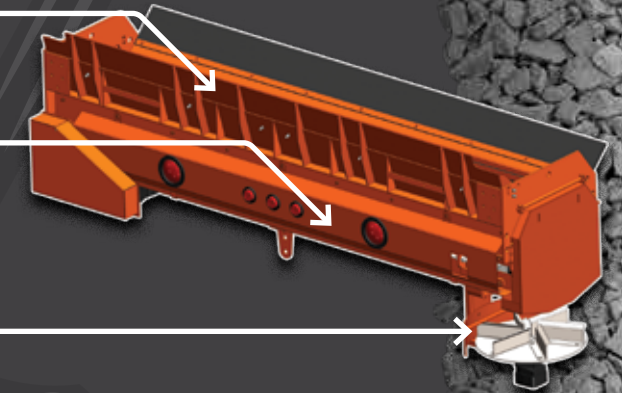

MOUNTING SYSTEM

CRE-960-18SL • Self-Leveling mounting system, includes upper pivot arms and lower pivot structure to keep machine level through various body angles.

AUGER EXTENSION

CRE-960-18AU • 60" adjustable auger extension, allowing material to be conveyed at an incline for general purpose fill.

DISCHARGE DOOR

CRE-960-18CD • Manually adjustable discharge door.

POWER PACK

CRE-960-18HP • Self-contained portable hydraulic power pack, includes electric start gasoline powered engine, direct mount hydraulic pump & reservoir, flow control valve and return line filter assembly on a removable platform. Hydraulic circuit can be used to power external tools.

LEG AND WINCH MOUNT

CRE-960-18FL • Folding leg and winch mounting system, includes folding legs for storage and transfer between units, winch leveling system, and chain mounting components.

CONVEYOR EXTENSION

CRE-960-18EX • 48" fold up conveyor extension, extends material drop point approximately 4ft. Standard curbside mount.

